

**SCREEN  
RESEARCH™**





# Your Personal Screening Room

Brought to you by Screen Research, the specialist in home cinema projection screens. Escape into your personal home theater. Savor the elegance, drama and mystery of Hollywood's finest from the comfort of your favorite chair. Experience the magic of cinema as it was meant to be seen. And heard.

**Come. Play. Travel beyond the ordinary.**

# The Finest Screen Materials

The heart of any screen is the fabric, the surface responsible for reflection and creation of the projected image. At Screen Research a rigorous program of continuous research and development ensures that we stay ahead of the game, bringing the best in fabric technology to bear on any cinematic application.

We continue to work with the industry's leading certification bodies to bring reference performance into every aspect of our fabrics. Our close collaboration with THX<sup>®</sup> and ISF<sup>®</sup> ensure that we always meet and exceed the requirements for re-creating the ultimate cinema experience right in your own home theater.

**Only the finest can truly deliver on that promise.**





## ClearPix

Screen Research's award-winning truly acoustically transparent screen solutions help recreate that larger-than-life experience in your very own living room or dedicated home theater. As with the finest cinemas around the globe, the entire front sound stage - left-center-right speakers – can be placed directly behind the screen at the same horizontal axis, so that vocals and special effects are in complete synchronization with the moving images. Screen Research's patented ClearPix™ acoustically transparent screen surfaces are certified by the ISF® (Imaging Science Foundation) for optimum video performance, plus THX® acoustic performance certifications for optimum audio performance – the industry's leading marks of excellence.



## SolidPix



SolidPix™ fabrics provide the ideal solution for theater applications where the acoustic transparency of ClearPix™ is not required. The Flat Spectral Response characteristics of our ISF®-certified SolidPix™ fabrics provide incredible color fidelity and a wide viewing angle with no hotspots, to bring out the best in your projected cinema images exactly as the director intended. These fabrics are available in both gray and white to suit a wide range of partnering projectors, ambient lighting levels and theater environments.

## MultiPix



Screen Research's ISF®-certified MultiPix™ range of screen fabrics provide a variety of solutions for positive gain requirement and ambient light conditions. Their unique Multi-layer design provides the enhanced gain required for multi-purposes room use whilst maintaining perfect color balance and white field uniformity required for ISF® certification.

In contrast with conventional gain coating techniques, Screen Research's proprietary Multi-layer technology offers application-specific flexibility combined with scientifically controlled manufacturing. This allows consistent performance, durability in use and 4K-ready detail resolution.



# Reference, Supreme and Classic Line

Screen Research's handcrafted, European-built screen solutions are engineered to meet the most challenging design and installation requirements. Our industrial capabilities include the most sophisticated "made on order" screen manufacturing processes and we have designed and built state-of-the-art manufacturing plants that are second to none.

We offer an expansive palette of customized solutions, such as our leather frame and personalized DécorMask system, that creates the perfect, individual Home Cinema experience, every time.

At Screen Research, each member of the team has a passion for what we do, continuously pushing the boundaries on how to create the best experience in home theater. This is what drives us forward to develop new products, new fabrics and explore new applications. Knowing that our products help deliver the entire range of human emotions through the power of the cinema, means that we have the best job in the world.

**Screen Research - Only Where Excellence is Required.**





# X-Mask. The Reference.

X-Mask™ Theater Curve  
4 Way masking system

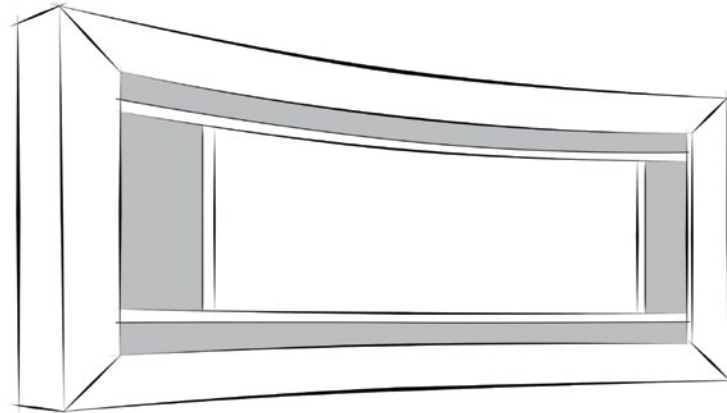

If you want to create the ultimate cinema experience at your home and you are not willing to compromise, look no further than our X-Mask™. With our most advanced 4-way masking system available together with an optional curved frame it is designed as a true state-of-the-art reference in our industry.

Fully compatible with PMI concept developed by Anthony Grimani, it can display any aspect ratio at different image sizes based on the content resolution. It is a Hollywood director's dream come true.

Our optional DécorMask™ system allows us to print any image on a separated roller surface, so while not in use it can disappear while showing any work of art or any image of your choice. Full Closure is another available option, allowing the screen masks to remain safely closed for complete screen protection while not in use.

## Reference Cinema Performance.



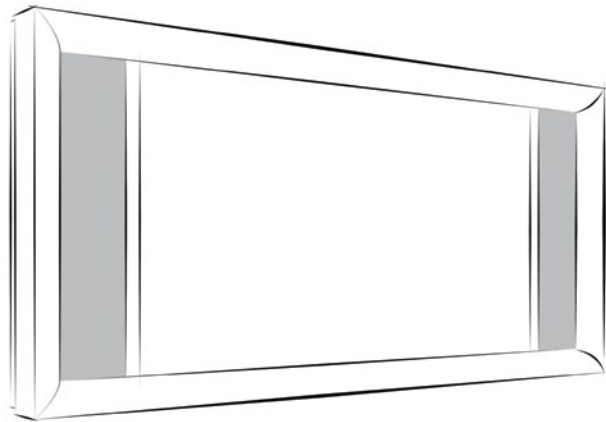

## E-Mask. Real Cinema.

There is only one way to watch a 2.40:1 aspect ratio image as it was meant to be: wider than 16/9. To make this concept more affordable we have created the E-Mask™. Designed to perfectly compliment a new mid-range videoprojectors that are capable of properly displaying a wider 2.35:1 image, with or without anamorphic lens. It is available in two versions: with Lateral or Top/Bottom masking system.

**Real Cinema at Home. Finally.**



When Harry Met Sally...  
Platonic friends develop a mutual attraction while helping each other through a variety of bad relationships.

## Le Wing. The One.

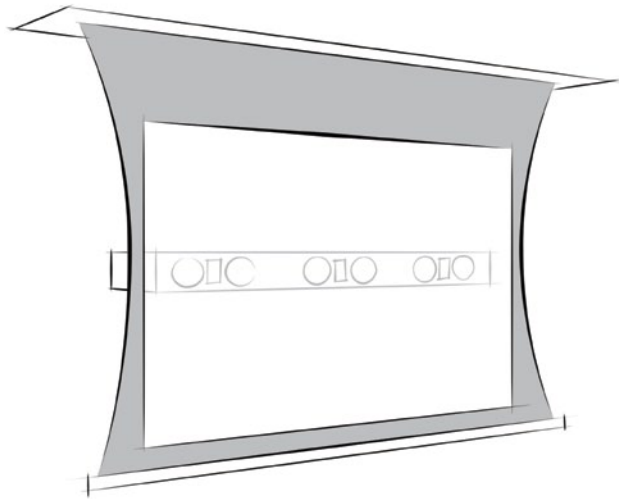

Sometimes we are told that some things are impossible. Like having a Reference Home Theater audio-video system in a Living room that completely disappears when not in use. But what if...? It is the enquiring minds of Screen Research's engineering team that allowed us to come up with cutting-edge application such as this. LeWing™ is an innovative sight and sound screen solution, that disappears as gracefully as it appears. We have built a Reference audio system using JBL Synthesis loudspeakers that disappears completely in the ceiling together with screen when not used. And when used, the loudspeakers are positioned in the only proper way: behind the screen. With no compromises, audio or video, thanks to ClearPix™.

LeWing™ is the perfect solution for spaces or venues that present unique installation challenges – such as in front of a glass or mirrored wall, directly in front of a fireplace, or even flown down in the middle of a room.

If you do not want to compromise on the audio/video performance and on your living room aesthetics, there is no other solution with this level of flexibility and state-of-the-art performance.

**LeWing: Think possible. Enjoy the impossible.**



# Supreme DualFormat

Supreme series allows for the widest range of custom features in our entire product line. From a 4-way motorized screens to a solutions that integrate both the screen surface and a motorized blind. This allows the screen to be mounted even in front of the windows with direct sunlight, while protecting the delicate screen surface from any damage.

ISF<sup>®</sup> Day – Night: A whole new concept with Supreme Dual-Format.

If you use your Home Theater in different lighting conditions, such as Day and Night viewing, ISF<sup>®</sup> requires that the projector is calibrated separately for two different ambient light conditions. Supreme series motorized Dual-Format screens allow to take this approach to another level by integrating two different screen materials in the same screen: one surface for Day viewing (Grey screen material) and another for Night (White screen material) viewing ambient light conditions. This way you can have best of both worlds: highest quality image optimized for late night viewing and a dedicated screen surface designed to reject ambient light and look best with some light in the room.

**Supreme: The “Reference” in custom solutions.**

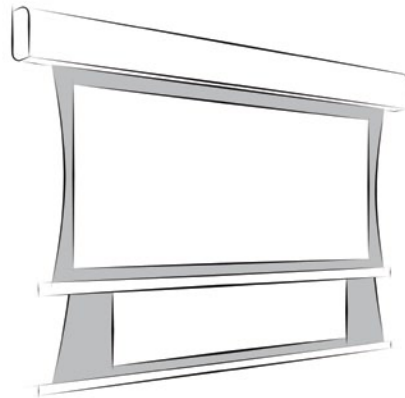

Supreme Dual-Format  
2 aspect ratio option



Supreme Dual-Format  
2 projection surface type option





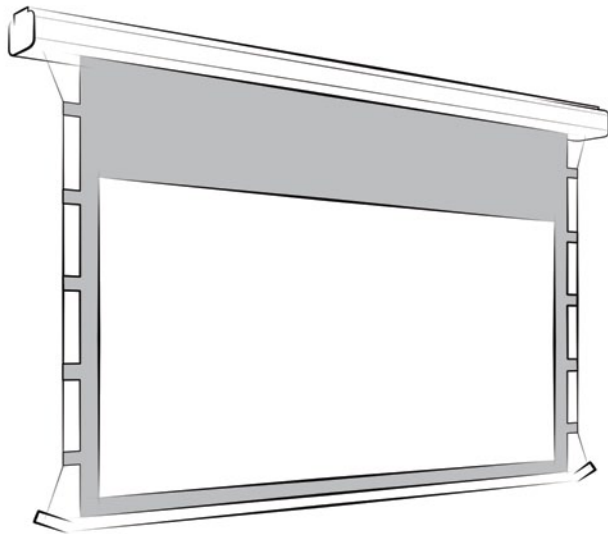

Classic Line On-Wall with CTS, self-adjusting  
Constant Tension System

## Classic Line

Classic Line by Screen Research: an affordable range of high quality video projection screens that offers advanced design features unmatched before in this price category, as the highly recognized ISF<sup>®</sup> certified SolidPix<sup>™</sup> screen materials for superior image fidelity and the self-adjusted Constant Tensioning System for perfect flatness that does not require any maintenance.

Classic Line screens are available as Fixed Frame screens, and both On-Wall and In-Ceiling motorized solutions.

**Never out of fashion. True Classic.**



# Product Range

## Fixed Frame Screens

Supreme 3 TheaterCurve	Supreme 3	Classic 2	Classic Line TheaterCurve	Classic Line	Integrator I-Type Shallow	Integrator I-Type Deep	Integrator J-Type
<p>Art. Code: T-FS3</p> <p>&gt; Maximum standard* width: Up to 160"</p> <p>&gt; Available Fabrics: ClearPix2 and ClearPix3 MultiPix SolidPix and SolidPix1</p>	<p>Art. Code: FS3</p> <p>&gt; Maximum standard* width: Up to 160"</p> <p>&gt; Available Fabrics: ClearPix2 and ClearPix3 MultiPix SolidPix and SolidPix1</p>	<p>Art. Code: FC2</p> <p>&gt; Maximum standard* width: Up to 120"</p> <p>&gt; Available Fabrics: ClearPix3 SolidPix0 and SolidPix0</p>	<p>Art. Code: T-CLF</p> <p>&gt; Maximum standard* width: Up to 120"</p> <p>&gt; Available Fabrics: SolidPix MultiPix PerfPix</p>	<p>Art. Code: CLF</p> <p>&gt; Maximum standard* width: Up to 120"</p> <p>&gt; Available Fabrics: SolidPix MultiPix PerfPix</p>	<p>Art. Code: FIS</p> <p>&gt; Maximum standard* width: Up to 160"</p> <p>&gt; Available Fabrics: ClearPix2 and ClearPix3 MultiPix SolidPix and SolidPix1</p>	<p>Art. Code: FID</p> <p>&gt; Maximum standard* width: Up to 160"</p> <p>&gt; Available Fabrics: ClearPix2 and ClearPix3 MultiPix SolidPix and SolidPix1</p>	<p>Art. Code: FJ</p> <p>&gt; Maximum standard* width: Up to 160"</p> <p>&gt; Available Fabrics: ClearPix2 and ClearPix3 MultiPix SolidPix and SolidPix1</p>

## Fixed Frame Screens with Masking

Reference X-Mask 4-Way TheaterCurve	Reference X-Mask Top-Bottom TheaterCurve	Reference X-Mask Lateral TheaterCurve	Reference X-Mask 4-Way	Reference X-Mask Top-Bottom	Reference X-Mask Lateral	Classic E-Mask Top-Bottom	Classic E-Mask Lateral
<p>Art. Code: T-X4R</p> <p>&gt; Maximum standard* width: Up to 160"</p> <p>&gt; Available Fabrics: ClearPix2 and ClearPix3 MultiPix SolidPix and SolidPix1</p>	<p>Art. Code: T-XTR</p> <p>&gt; Maximum standard* width: Up to 160"</p> <p>&gt; Available Fabrics: ClearPix2 and ClearPix3 MultiPix SolidPix and SolidPix1</p>	<p>Art. Code: T-XLR</p> <p>&gt; Maximum standard* width: Up to 160"</p> <p>&gt; Available Fabrics: ClearPix2 and ClearPix3 MultiPix SolidPix and SolidPix1</p> <p>&gt; Full Closure option available</p>	<p>Art. Code: X4R</p> <p>&gt; Maximum standard* width: Up to 160"</p> <p>&gt; Available Fabrics: ClearPix2 and ClearPix3 MultiPix SolidPix and SolidPix1</p>	<p>Art. Code: XTR</p> <p>&gt; Maximum standard* width: Up to 160"</p> <p>&gt; Available Fabrics: ClearPix2 and ClearPix3 MultiPix SolidPix and SolidPix1</p>	<p>Art. Code: XLR</p> <p>&gt; Maximum standard* width: Up to 160"</p> <p>&gt; Available Fabrics: ClearPix2 and ClearPix3 MultiPix SolidPix and SolidPix1</p> <p>&gt; Full Closure option available</p> <p>&gt; DécorMask option available</p>	<p>Art. Code: ETC</p> <p>&gt; Maximum standard* width: Up to 120"</p> <p>&gt; Available Fabrics: ClearPix2 and ClearPix3 MultiPix SolidPix and SolidPix1</p> <p>&gt; Low Masking Distance</p>	<p>Art. Code: EL1C</p> <p>&gt; Maximum standard* width: Up to 140"</p> <p>&gt; Available Fabrics: ClearPix2 and ClearPix3 MultiPix SolidPix and SolidPix1</p> <p>&gt; Low Masking Distance</p>

\* All dimensions out of standard are available upon request.

## On-Ceiling Motorized Screens

Supreme 2	Supreme 2 Top	Supreme 2 Lateral	Supreme 2 Lateral 2	Supreme Line MultiFormat	Supreme Line DualFormat	Classic Line	Classic Line	Classic 2
Art. Code: MS2	Art. Code: MMS2-T	Art. Code: MMS2-L1	Art. Code: MMS2-L2	Art. Code: SLMF	Art. Code: SLDF	Art. Code: CLCLT	Art. Code: CLCTS	Art. Code: MC2
> Maximum standard* width: Up to 160"	> Maximum standard* width: Up to 160"	> Maximum standard* width: Up to 160"	> Maximum standard* width: Up to 110"	> Maximum standard* width: Up to 110"	> Maximum standard* width: Up to 120"	> Maximum standard* width: Up to 120"	> Maximum standard* width: Up to 120"	> Maximum standard* width: Up to 110"
> Available Fabrics: ClearPix2 and ClearPix3 MultiPix SolidPix and SolidPix1	> Available Fabrics: ClearPix2 and ClearPix3 MultiPix SolidPix and SolidPix1	> Available Fabrics: ClearPix2 and ClearPix3 MultiPix SolidPix and SolidPix1	> Available Fabrics: ClearPix2 and ClearPix3 MultiPix SolidPix and SolidPix1	> Available Fabrics: SolidPix and SolidPix1  > Low Masking Distance	> Available Fabrics: SolidPix and SolidPix1	> Available Fabrics: PerfPix SolidPix	> Available Fabrics: PerfPix SolidPix  > Tentioning System: Constant Tention System	> Available Fabrics: ClearPix2 and ClearPix3 MultiPix SolidPix and SolidPix1

## In-Ceiling Slot Motorized Screens

Supreme 2	Supreme 2 Top	Supreme 2 Lateral	Supreme 2 Lateral 2	Classic Line
Art. Code: MS2-IS	Art. Code: MMS2-T-IS	Art. Code: MMS2-L1-IS	Art. Code: MMS2-L2-IS	Art. Code: CLIC
> Maximum standard* width: Up to 160"	> Maximum standard* width: Up to 160"	> Maximum standard* width: Up to 160"	> Maximum standard* width: Up to 160"	> Maximum standard* width: Up to 120"
> Available Fabrics: ClearPix2 and ClearPix3 MultiPix SolidPix and SolidPix1	> Available Fabrics: ClearPix2 and ClearPix3 MultiPix SolidPix and SolidPix1	> Available Fabrics: ClearPix2 and ClearPix3 MultiPix SolidPix and SolidPix1	> Available Fabrics: ClearPix2 and ClearPix3 MultiPix SolidPix and SolidPix1	> Available Fabrics: PerfPix SolidPix

## In-Ceiling Trap Motorized Screens

Supreme 2	LeWing Top	LeWing Lateral
Art. Code: MS2-IT	Art. Code: W3M-T-IT	Art. Code: W3M-L-IT
> Maximum standard* width: Up to 110"	> Maximum standard* width: Up to 110"	> Maximum standard* width: Up to 120"
> Available Fabrics: ClearPix2 and ClearPix3 MultiPix SolidPix and SolidPix1	> Available Fabrics: ClearPix2	> Available Fabrics: ClearPix2

\* All dimensions out of standard are available upon request.



**Screen Research**

Tel: +48 76 850 53 01  
info@screenresearch.com  
www.screenresearch.com

Screen Research is a brand of Adeo Screen

**Adeo Screen**

Bolesława Krzywoustego 31, 59-500 Złotoryja,  
Poland

Tel: +48 76 850 53 01  
info@adeoscreen.com  
www.adeoscreen.com

Adeo Screen is a property of Adeo Group Inc.,  
Italy

ClearPix, ClearPix2, SolidPix, SolidPix1,  
GrayPix, X-Mask, E-Mask, LeWing,  
TheaterCurve, Pi-Grip, FastGrip, TFX,  
StopLight, DécorMask and the Screen  
Research logo are all trademarks of Screen  
Research.

THX is a trademark of THX Ltd.  
ISF is a trademark of Imaging Science  
Foundation Inc.

All other trademarks are the property of their  
respective owners.

Screen Research products are covered by one  
or more of the following patents:

Euro Patent Delivered n° 1676172  
Euro Patent Delivered n° 1627555  
US Patent Delivered: US7777947B2  
US Patent Delivered n° 7466483B2  
China Patent Delivered n° ZL2004800252609  
India Patent Delivered n° 1126/CHENP/2007

© Copyright 2012 Adeo Screen.  
All rights reserved.



