

DXP HD 4K Series

4K HDMI MATRIX SWITCHERS WITH AUDIO DE-EMBEDDING

Reliable, High Performance Switching of HDMI Video and Audio Signals



- ▶ Available in 4x4, 8x4, 8x8, 16x8, and 16x16 fixed I/O sizes
- ▶ Supports computer and video resolutions up to 4K, including 1080p/60 Deep Color
- ▶ HDMI audio de-embedding with digital S/PDIF and analog stereo outputs
- ▶ Includes EDID Minder®, Key Minder®, and SpeedSwitch® technologies that ensure fast, reliable switching
- ▶ Easy setup and commissioning with Extron's PCS - Product Configuration Software
- ▶ Ethernet configuration, monitoring, and control



Introduction

The Extron **DXP HD 4K Series** are high performance HDMI matrix switchers for computer and video resolutions up to 4K. They support HDMI specifications including data rates to 10.2 Gbps, Deep Color up to 12-bit, 3D, and HD lossless audio formats. DXP HD 4K Series matrix switchers incorporate Extron technologies such as SpeedSwitch®, EDID Minder®, and Key Minder® as well as HDMI equalization and output regeneration to ensure reliable system operation. In addition, digital audio can be de-embedded from any input and assigned to digital or analog stereo outputs for ease of integration. Available in fixed I/O sizes from 4x4 to 16x16, the DXP HD 4K Series is ideal for applications that require reliable, high performance switching of HDMI video and audio signals between multiple sources and displays.

The DXP HD 4K Series matrix switchers are designed for use with computers equipped with 4K graphics cards, media players and similar signal sources, as well as 4K native resolution displays. With a maximum data rate of 10.2 Gbps, the switchers support computer and video resolutions up to 4096x2160 @ 30 Hz with 8-bit color in 4:4:4 color space. In addition, these matrix switchers fully support 1080p/60 with 12-bit Deep Color. To maintain signal integrity, the matrix switchers feature automatic cable equalization on inputs and output reclocking to reshape and restore timing of the video signal at each HDMI output. These features combined with Extron Pro Series High Speed HDMI Cables allow longer 4K signal runs, reducing the need for additional signal conditioning equipment by compensating for weak source signals or signal loss on long cable runs. Additionally +5 VDC, 200 mA is available on the outputs for powering peripheral devices.

Flexible Audio Distribution

Audio routing in the DXP HD 4K Series is handled in two ways. Embedded digital audio from a source can be switched along with its corresponding video signal to any or all selected HDMI outputs. In addition, built-in audio de-embedders allow audio to be routed to

discrete digital or analog audio outputs. The internal de-embedders eliminate the need for external HDMI audio extraction products, reducing the number of boxes in the AV system and system complexity and maintenance costs. For applications requiring digital audio distribution, the de-embedded audio is made available on S/PDIF outputs in its native two-channel or multi-channel Dolby® Digital or DTS format. For analog audio applications, the de-embedded signal is made available as line level stereo audio on captive screw connectors. These audio outputs simplify integration with the local audio system.

Fast Reliable Switching

For enhanced integration of HDMI-equipped sources and displays, the DXP HD 4K Series features two Extron technologies: EDID Minder and Key Minder. EDID Minder automatically manages EDID communications, ensuring that all HDMI sources power up properly and reliably deliver content whether or not they are actively connected to the display devices through the matrix switcher. For HDMI signals with protected content, Key Minder authenticates and maintains continuous HDCP encryption between input and output devices to ensure quick and reliable switching in professional AV environments while enabling simultaneous distribution of a single source signal to one or more displays. If a signal from an HDCP-compliant source is routed to a non-compliant display, the switcher outputs a full-screen green signal, providing immediate visual confirmation that the protected content cannot be viewed on the selected display. With SpeedSwitch Technology, the DXP HD 4K matrix switchers deliver exceptional, virtually instantaneous switching speeds for HDCP-encrypted content.

Easy Setup, Monitoring, and Control

The matrix switchers also provide advanced system monitoring and control via the RS-232 and Ethernet ports. Global presets allow for simplified configuration changes and fast switching speed when using a separate control system to operate the matrix switcher. Front panel indicators provide visual feedback of routing, signal presence on all inputs and outputs, and the presence of HDCP encrypted content on each input. For ease in configuration and commissioning, Extron's PCS - Product Configuration Software provides a simple consistent software interface to setup the DXP HD 4K matrix switchers using an interface common to many Extron products.

With I/O sizes up to 16x16, the DXP HD 4K Series can provide AV signal switching for applications such as videowalls, command and control environments, emergency operations centers, and divisible meeting rooms, or for a centralized control room supporting adjacent classrooms. The DXP HD 4K matrix switchers are ideal for a wide variety of professional AV installations where distribution of high resolution, digital video signals is needed and a fully digital pathway is essential to maintain the highest possible image quality between multiple sources and displays.



A DXP HD 4K matrix switcher installed in a central control room can support two or more adjacent classrooms.

Features

Available in 4x4, 8x4, 8x8, 16x8, and 16x16 fixed I/O sizes

Supports computer and video resolutions up to 4K, including 1080p/60 Deep Color

Supported HDMI specification features include data rates up to 10.2 Gbps, Deep Color up to 12-bit, 3D, and HD lossless audio formats

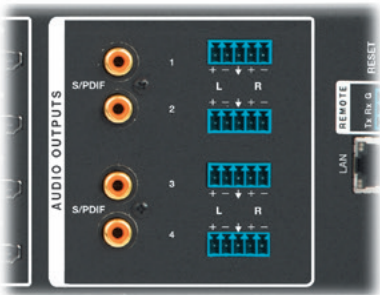

HDMI audio de-embedding with digital S/PDIF and analog stereo audio outputs

The DXP HD 4K Series can extract embedded HDMI two-channel LPCM audio to S/PDIF digital and analog audio outputs. It can also extract Dolby® or DTS® encoded bitstream audio to the S/PDIF outputs. Multiple sets of S/PDIF and analog outputs, support audio assignment from any source.

HDCP compliant

Ensures display of content-protected media and interoperability with other HDCP-compliant devices.

User-selectable HDCP authorization

Allows the unit to appear HDCP compliant or non-HDCP compliant to the connected source, which is beneficial if the source automatically encrypts all content when connected to an HDCP-compliant device. Protected material is not passed in non-HDCP mode.

SpeedSwitch® Technology provides exceptional switching speed for HDCP-encrypted content

Key Minder® continuously verifies HDCP compliance

Key Minder authenticates and maintains continuous HDCP encryption between input and output devices to ensure quick and reliable switching, while enabling simultaneous distribution of a single source to one or more displays.

HDCP Visual Confirmation provides a green signal when encrypted content is sent to a non-compliant display

A full-screen green signal is sent when HDCP-encrypted content is sent to a non-HDCP compliant display, providing visual confirmation that protected content cannot be viewed on the display.

EDID Minder® automatically manages EDID communication between connected devices

Ensures that all sources power up properly and reliably output content for display.

Supports DDC transmission

Automatic or manual color bit depth management

Automatically adjusts color bit depth based on the display EDID, preventing color compatibility conflicts between source and display. Alternately, the color bit depth can be set manually for each output.

HDMI to DVI Interface Format Correction

Automatically reformats HDMI source signals for output to a DVI display.

View I/O mode

Discrete LEDs or tri-color buttons for each input so users can easily view which inputs and outputs are actively connected for ease in troubleshooting.

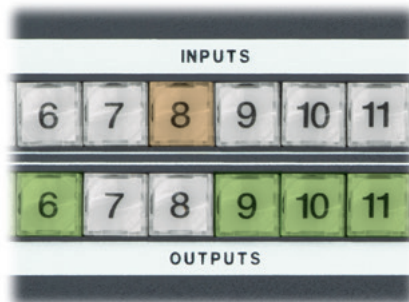

Tri-color, backlit buttons - 16x8, 16x16 I/O

Can be custom labeled for easy identification. The buttons illuminate red, green, or amber, depending on function, for ease of use in low-light environments.

Automatic cable equalization

Equalizes input signals to support longer cables at resolutions up to 4K.

Automatic output reclocking

Reshapes and restores timing of HDMI signals at each output, enabling transmission over long HDMI cables.

Provides +5 VDC, 200 mA power on the HDMI outputs for external peripheral devices

Global presets

Up to 32 I/O configurations may be saved and recalled from the front panel, Ethernet, or serial control. This time-saving feature allows I/O configurations to be set up and stored in memory for future use.

QS-FPC™ QuickSwitch Front Panel Controller

Discrete buttons for each input and output allow for simple, intuitive operation.

Ethernet monitoring & control

Can be proactively monitored, managed, or controlled over a LAN, WAN, or the Internet using standard TCP/IP protocols.

RS-232 control port

Using serial commands, the matrix switcher can be integrated into a control system. Extron products use the SIS™ – Simple Instruction Set command protocol, a set of basic ASCII code commands that allow for quick and easy programming.

Easy setup and commissioning with Extron's PCS – Product Configuration Software

Conveniently configure multiple products using a single software application.

Front panel USB configuration port

Enables easy setup, configuration, and firmware updating without having to access the rear panel.

Front panel security lockout

Prevents unauthorized use in non-secure environments.



DXP 88 HD 4K

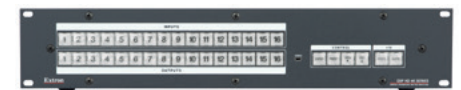

DXP 1616 HD 4K

Rack-mountable full rack width metal enclosure

1U – 4x4, 8x4, and 8x8 I/O
2U – 16x8 and 16x16 I/O

Highly reliable, energy-efficient internal universal power supply

Applications

Divisible Rooms

Many facilities include divisible spaces, which optimizes room usage for training, meetings, and social gatherings. At the same time, these rooms can complicate technology implementation due to the large number of sources and displays that need to be used in the individual or combined spaces. A single matrix switcher that can be easily addressed by a control system is ideal for divisible spaces.

The DXP HD 4K PLUS Series matrix switchers provide centralized signal routing of video signals up to 4K resolutions with embedded audio. Outputs can be grouped or zoned to match different room configurations. Each matrix switcher provides audio de-embedding from digital and analog signals for independent processing and distribution to a sound system. These features make the DXP HD 4K PLUS Series ideal for supporting divisible spaces in a wide variety of room configurations.

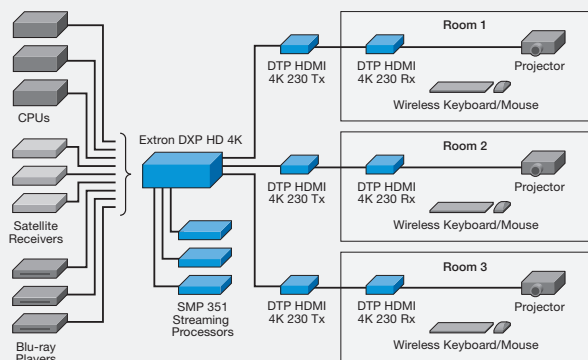

Emergency Operations Centers

Emergency Operations Centers - EOC allow various government agencies to work together to monitor, assess, and resolve situations in times of natural disasters or local emergencies. This type of space requires an AV system that provides reliable, high performance signal routing in real time. Typically, the main display is a videowall or other large display system for optimal visibility by the various agencies. Individual displays allow agency personnel to monitor specific areas of interest, such as transportation, fire and emergency response, and law enforcement efforts.

With up to 16 inputs and outputs, the DXP HD 4K Series can route high resolution mapping or GIS content, which is often required in an EOC. Videowalls alone may use as many as eight switcher outputs to feed windows from computers or traffic cameras. With 16 outputs, the matrix switcher still has outputs available to support individual displays within the same room or in adjacent spaces. The I/O count and high resolution video capacity of the DXP HD 4K Series serve these mission-critical facilities well.

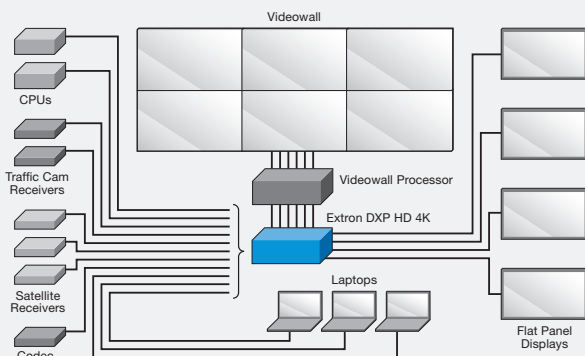

Overview

Key Minder®

Continuously verifies HDCP compliance for quick, reliable switching while enabling simultaneous distribution of a single source to one or more displays.

4K/60 @ 4:4:4

Provides high performance switching and distribution of computer and video resolutions up to 4096x2160.

EDID Minder®

Automatically manages EDID communication between connected devices, ensuring that all sources power up properly and reliably output content for display.

SpeedSwitch® Technology

Provides exceptional switching speed for HDCP-encrypted content.



Fixed I/O Sizes
16x8, and 16x16 in 2U Enclosure

Automatic input cable equalization

Actively conditions incoming HDMI signals to compensate for signal loss when using long cables, low quality cables, or source devices with poor HDMI signal output. 4K/60 signals are equalized to 35 feet (10.7 meters) when used with Extron HDMI Pro cables.

HDMI audio de-embedding

Encoded Dolby or DTS multi-channel audio or two-channel audio can be extracted to S/PDIF or analog audio outputs.

Ease of Control

Can be proactively monitored, managed, or controlled over a LAN, WAN, or the Internet using standard TCP/IP protocols.



Fixed I/O Sizes
4x4, 8x4 and 8x8 in 1U Enclosure

Audio De-embedding

The DXP HD 4K PLUS Series features built-in audio de-embedders that allow independent distribution on digital multi-channel or analog stereo outputs. Mixers or DSP processors can be connected directly to the matrix switcher without the cost and complexity of additional audio de-embedding equipment. For flexible audio routing, native Dolby® Digital or DTS format multi-channel digital audio can be assigned to S/PDIF outputs and native two-channel audio can be assigned to both S/PDIF and analog stereo outputs. This enables a single centrally located DXP HD 4K PLUS matrix switcher to route independent video and audio signals to multiple locations.

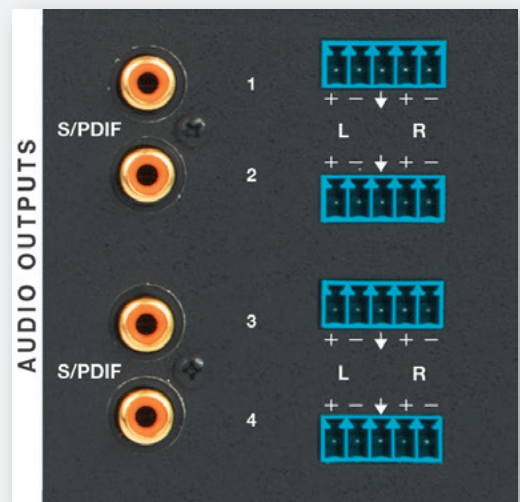

Specifications

TRUE 4K SPECIFICATION

Max 4K Capabilities

Resolution and Frame Rate	Chroma Sampling	Max Bit Depth per Color
4096 x 2160 at 30 Hz 3840 x 2160 at 30 Hz 4096 x 2160 at 60 Hz 3840 x 2160 at 60 Hz	4:4:4 4:2:0	8 bit

Frame Rate¹ 24, 25, 30, 50, or 60 fps

Color Sampling¹ 4:4:4, 4:2:2, or 4:2:0

Color Bit Depth¹ 8, 10, or 12 bits per color

Signal Type HDMI / HDCP

Max Video Data Rate 10.2 Gbps (3.4 Gbps per color)

NOTE¹: Subject to the maximum data rate limit. Use our calculator to find out max signal data rate.

VIDEO

Routing

DXP 88 HD 4K Series	4 x 4 matrix 8 x 4 matrix 8 x 8 matrix
DXP 1616 HD 4K Series	16 x 8 matrix 16 x 16 matrix

Maximum data rate 10.2 Gbps (3.4 Gbps per color)

Maximum pixel clock 300 MHz

Resolution range Up to 2560x1600* @ 60 Hz or 4K (4096x2160) @ 30 Hz, UHD (3840x2160) @ 30 Hz (*2560x1600 with reduced blanking)

Standards DVI 1.0, HDMI 1.4, HDCP 1.3, CEA-861E

VIDEO INPUT

Number/signal type

DXP 88 HD 4K Series	4 or 8 HDMI digital video (HDCP compliant)
DXP 1616 HD 4K Series	16 HDMI digital video (HDCP compliant)

Connectors

DXP 88 HD 4K Series	4 or 8 female HDMI
DXP 1616 HD 4K Series	16 female HDMI

VIDEO OUTPUT

Number/signal type

DXP 88 HD 4K Series	4 or 8 HDMI digital video (HDCP compliant)
DXP 1616 HD 4K Series	8 or 16 HDMI digital video (HDCP compliant)

Connectors

DXP 88 HD 4K Series	4 or 8 female HDMI
DXP 1616 HD 4K Series	8 or 16 female HDMI

AUDIO – INDIVIDUAL AUDIO GROUPS (HDMI)

Gain Unbalanced output, -6 dB; balanced output, 0 dB

Frequency response 20 Hz to 20 kHz, ± 0.2 dB

THD + Noise

DXP 88 HD 4K Series	0.03% @ 1 kHz at nominal level
DXP 1616 HD 4K Series	0.01% @ 1 kHz at nominal level

S/N

DXP 88 HD 4K Series	>90 dB at maximum output (unweighted)
DXP 1616 HD 4K Series	>105 dB at maximum balanced output (unweighted)

Crosstalk

DXP 88 HD 4K Series	<-80 dB @ 20 Hz to 20 kHz, fully loaded
DXP 1616 HD 4K Series	<-90 dB @ 20 Hz to 20 kHz, fully loaded

Stereo channel separation >80dB @ 20 Hz to 20 kHz

AUDIO OUTPUT

Number/signal type

DXP 88 HD 4K Series	4 or 8 HDMI, embedded 2 stereo, balanced or unbalanced 2 S/PDIF
DXP 1616 HD 4K Series	8 or 16 HDMI, embedded 4 stereo, balanced or unbalanced 4 S/PDIF

Connectors

DXP 88 HD 4K Series	4 or 8 female HDMI (2) 3.5 mm captive screw, 5 pole, for stereo 2 female RCA, for SPDIF
DXP 1616 HD 4K Series	8 or 16 female HDMI (4) 3.5 mm captive screw, 5 pole, for stereo 4 female RCA for S/PDIF

Impedance

Stereo audio	50 ohms unbalanced, 100 ohms balanced
S/PDIF	75 ohms

COMMUNICATIONS

Serial control port 1 bidirectional RS-232

Serial control connector (1) 3.5 mm captive screw, 3 pole (rear panel)

USB control port 1 front panel female USB mini-B

USB standards USB 2.0, low speed

Ethernet control port 1 female RJ-45 connector

Ethernet data rate 10/100Base-T, half/full duplex with autotdetect

GENERAL

Power supply

Internal
Input: 100-240 VAC, 50-60 Hz

Enclosure dimensions

DXP 88 HD 4K Series	1.75" H x 17.4" W x [9.5-12.0"] D (1U high, full rack wide) (4.4 cm H x 43.2 cm W x [24.1 - 30.5] cm D)
DXP 1616 HD 4K Series	3.5" H x 17.4" W x [9.75-12.0"] D (2U high, full rack wide) (8.9 cm H x 43.2 cm W x [24.8-30.5] cm D) (Depth excludes connectors and knobs. Width excludes rack ears.)

Warranty

3 years parts and labor

Model	Version Description	Part number
DXP 44 HD 4K	4x4 HDMI with 2 Audio Outputs	60-1493-01
DXP 84 HD 4K	8x4 HDMI with 2 Audio Outputs	60-1494-01
DXP 88 HD 4K	8x8 HDMI with 2 Audio Outputs	60-1495-01
DXP 168 HD 4K	16x8 HDMI with 4 Audio Outputs	60-1496-01
DXP 1616 HD 4K	16x16 HDMI with 4 Audio Outputs	60-1497-01

For complete specifications, please go to www.extron.com
Specifications are subject to change without notice.

WORLDWIDE SALES OFFICES

Anaheim • Raleigh • Silicon Valley • Dallas • New York • Washington, DC • Toronto • Mexico City • Paris • London • Frankfurt
Stockholm • Amersfoort • Moscow • Dubai • Johannesburg • Tel Aviv • Sydney • Melbourne • New Delhi • Bangalore
Singapore • Seoul • Shanghai • Beijing • Hong Kong • Tokyo

www.extron.com